

Features & Benefits:

Flexibility:

Applied typically when applications are beyond the scope of an electromagnetic drive. I.E. when units require length > 5 ft. and >18" width.

Gentle Handling:

Provides the absolute minimum vibration transfer insuring the gentlest handling of the product.

Easy Installation:

No major foundations are required; therefore installation is easy and inexpensive.

Reliability:

Because Gough designs its equipment to handle the specific application – it has year after year reliability.



◀ Twin rotary vibratory screen illustrating quick change screen for easy cleaning and optimum sanitation.

Gough feeder/screener powered by contra-rotating motors to remove excess sugar from jellied sweets. Hoppers available as shown here.



◀ Gough feeder/screeners are available in a variety of materials to meet food and industrial applications.

Tough, Gentle, Clean

Gough Econ, Inc.

P.O. Box 668583, Charlotte, NC 28266-8583

Phone: 800.264-6844 Fax: 704.392.8706

E-Mail: sales@goughecon.com

Website: www.goughecon.com

Form: twinrotary2.doc

Rev 0

Dimensional Data:

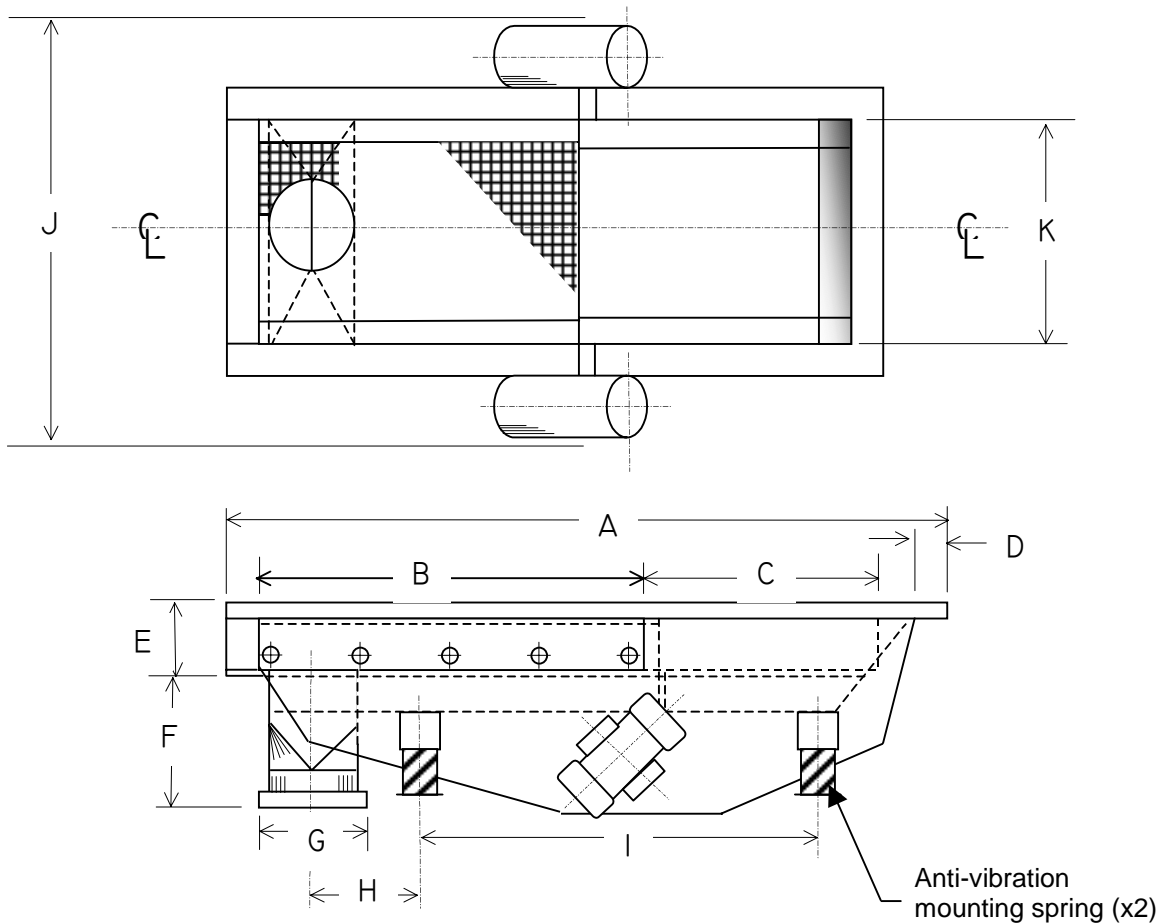

Dimensions (Inches)

A _____
B _____
C _____
D _____

E _____
F _____
G _____
H _____

I _____
J _____
K _____

Tough, Gentle, Clean